

Cable Ties

Miniature Fluorescent

- Material:** UL approved Nylon 66, 94V-2.
- Feature:** High tensile strength with low insertion force.
Excellent resistance to weathering and ageing.
Suitable for a multitude of uses in various industries.
- Application:** Self-locking for fast and easy application.
- Operating Temperature:** -40°C to +85°C.

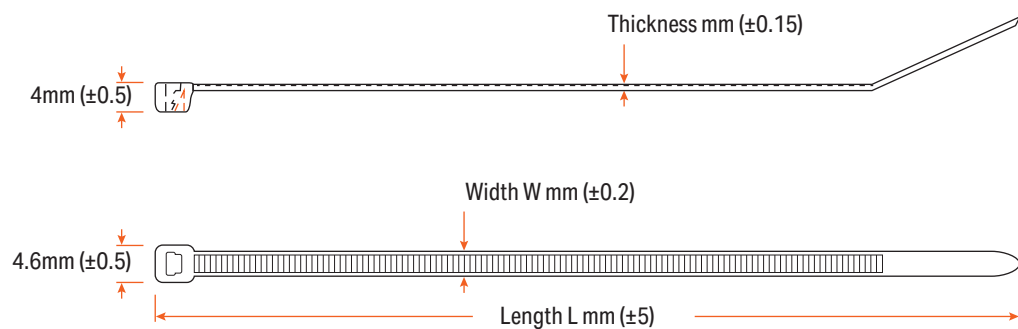
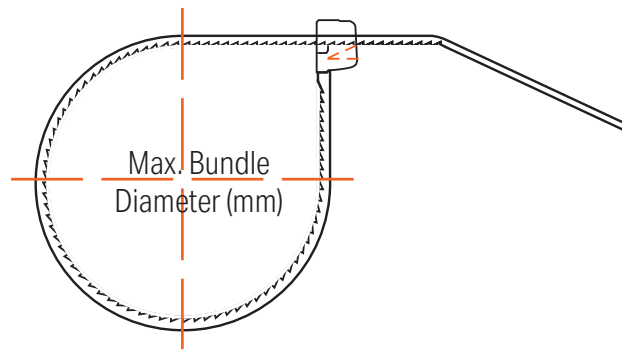
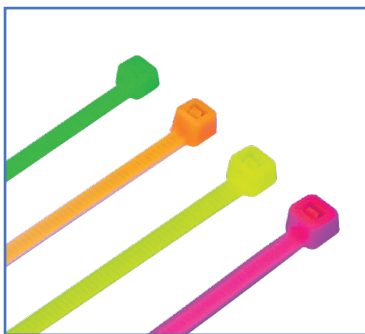

Item No.	Colour	Width W (mm)	Thickness (mm)	Length L (mm)	Max. Bundle Diameter (mm)	Min. Tensile Strength (kg)
TR1F-BLUE	Fluorescent Blue	2.5	1.1	100	22	8
TR1F-GREEN	Fluorescent Green	2.5	1.1	100	22	8
TR1F-ORANGE	Fluorescent Orange	2.5	1.1	100	22	8
TR1F-PINK	Fluorescent Pink	2.5	1.1	100	22	8
TR1F-YELLOW	Fluorescent Yellow	2.5	1.1	100	22	8

STORAGE AND USAGE OF NYLON CABLE TIES

BEAL UK cable ties are made from high quality Nylon 66 resin. Moisture absorption is an essential factor for this material to retain its strength and maintain optimal performance. To this end, it is important for the cable ties to be kept in a sealed package wherever possible.

Below are some helpful storage suggestions:

1. The ideal storage temperature is around 23°C with the humidity over 50%.
2. Do not open the bag before use. Please try to finish the whole package of cable ties shortly after opening or reseal the bag until you are ready to use again.
3. Do not expose directly under sunlight (except UV weather resistant cable ties).
4. Avoid storing cable ties close to warm objects (such as heaters).